

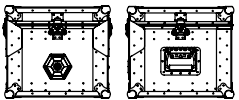

6T Series

CBSTC06T1, CBSTC06T2, CBSTC06T6

2/5/12 kWh
ECR



CBSTC06T1 2 KWH ECR

EXT: 19.2" x 19.0" x 16.6"h (48.8 x 48.3 x 42.2 cm)
INT: 11.1" x 10.6" x 9.9"h (28.2 x 26.9 x 25.1 cm)
TARE WT: 73.5 lbs (33.3 kg)

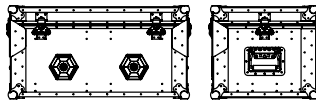

CBSTC06T2 5 kWh ECR

EXT: 32.2" x 19.2" x 16.6"h (81.8 x 48.8 x 42.2 cm)
INT: (2 compartments) 11.1" x 10.6" x 9.9"h
(28.2 x 26.9 x 25.1 cm)
TARE WT: 126 lbs (57.2 kg)

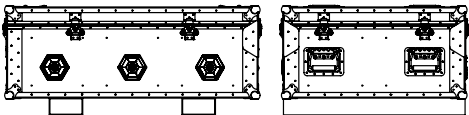

CBSTC06T6 12 KWH ECR

EXT: 46.3" x 33.5" x 19.4"h (117.6 x 85 x 49.3 cm)
INT: (6 compartments) 11.1" x 10.6" x 9.9"h
(28.2 x 26.9 x 25.1 cm)
TARE WT: 203 lbs (92 kg)



Tested beyond compliance. We subject our cases to "worst-case scenario" testing.

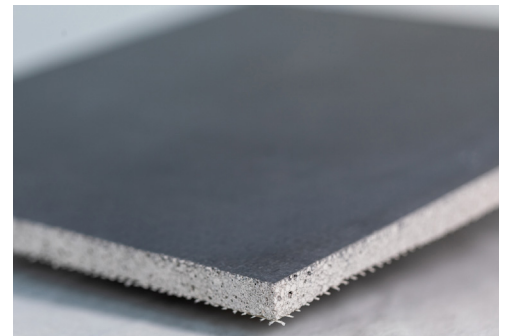

Lined with **FCP Technology** - CellBlock's patented composite lining

Tested and Proven Protection Specialty Battery Cases

CellBlock FCS offers intelligently engineered solutions to some of the battery industry's most challenging problems. Our focus is supporting companies and organizations that utilize stored energy in their day-to-day operations. Our 6T Series lithium-ion battery containment cases are designed with rugged use in mind.

- ✓ Sized for widely used 6T batteries
- ✓ Patented FCP Technology
- ✓ Thermal and ballistic protection
- ✓ Safe on-site storage of batteries
- ✓ Safe and compliant transportation of batteries, including damaged, defective, and prototype.
- ✓ UN rated and Special Permits 20549 and 21442 authorized
- ✓ RF Foam inserts provide precision fit protection
- ✓ Fork lift guides standard on 6-capacity case (CBSTC6T6)



Gas Mitigation System effectively releases pressure caused by the thermal degeneration of batteries.

CBSTC06T1 SPECIFICATIONS

1 Battery Capacity | 2 kWh ECR

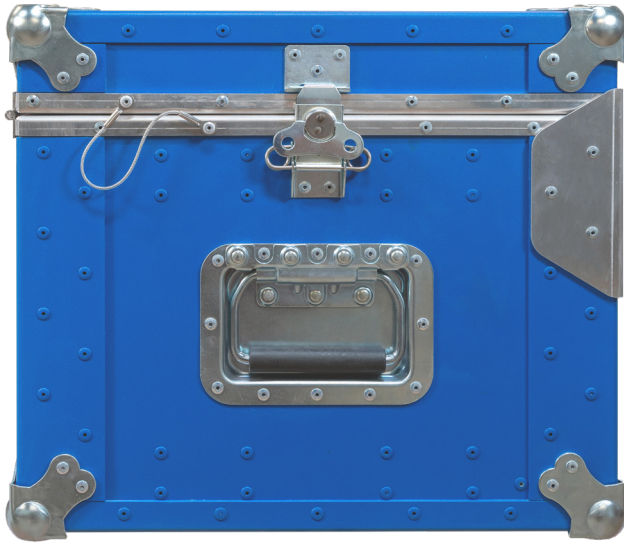

UN Mark	4B/X75/S/**/USA/M6484 ** year of manufacture
Exterior Dimensions	19.2" x 19.0" x 16.6"h 48.8cm x 48.3cm x 42.2cm
Interior Dimensions	1 Battery Compartment: 11.1" x 10.6" x 9.9"h 28.2cm x 26.9cm x 25.1cm h
Tare Weight	85 lbs 38.6 kg
Max. Content Weight	80.3 lbs max. 36.4 kg max.
Gross Weight Limit	165.3 lbs max. 75 kg max.

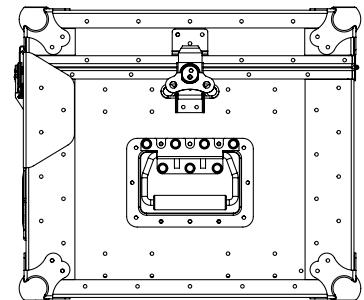
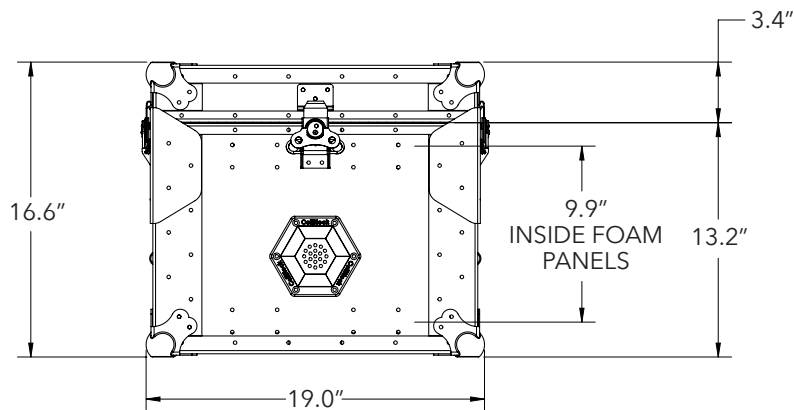
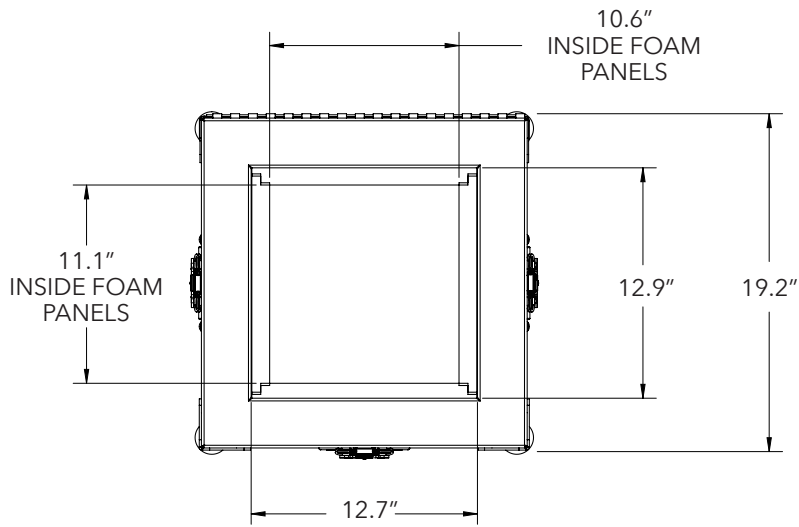

CBSTC06T2 SPECIFICATIONS

2 Battery Capacity | 5 kWh ECR

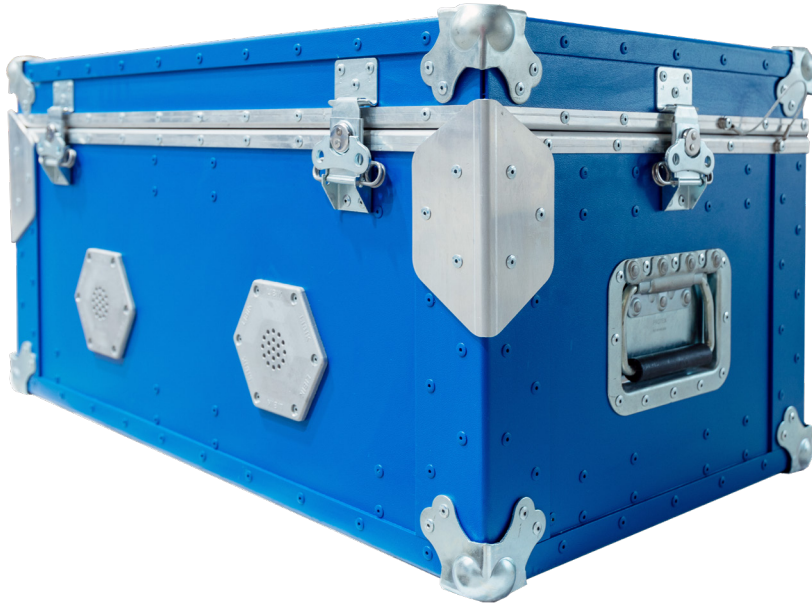

UN Mark	4B/X128/S/**/USA/M6484 <i>** year of manufacture</i>
Exterior Dimensions	32.2" x 19.2" x 16.6" 81.8cm x 48.8cm x 42.2cm
Interior Dimensions	2 Battery Compartments Each: 11.1" x 10.6" x 9.9" 28.2cm x 26.9cm x 25.1cm
Tare Weight	126 lbs 57.2 kg
Max. Content Weight	156.2 lbs max. 70.8 kg max.
Gross Weight Limit	282.2 lbs max. 128 kg max.

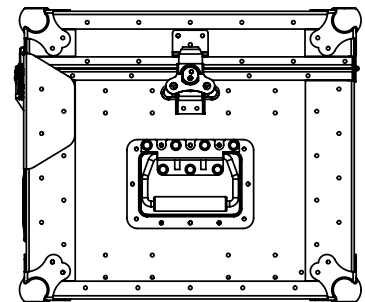
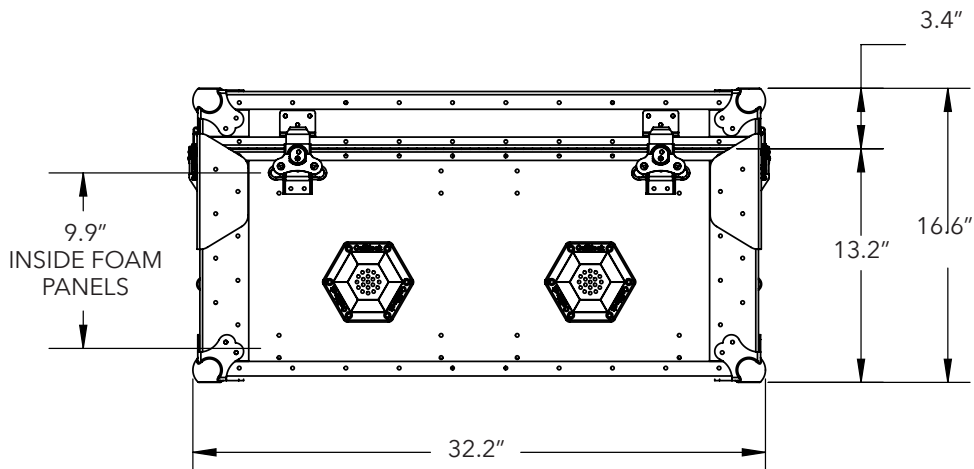
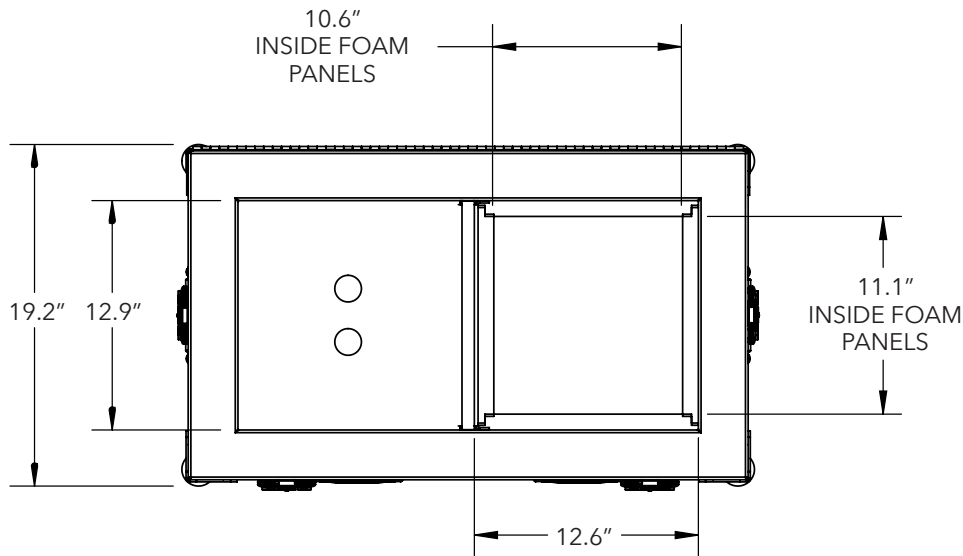

CBSTC06T6 SPECIFICATIONS

6 Battery Capacity | 12 kWh ECR

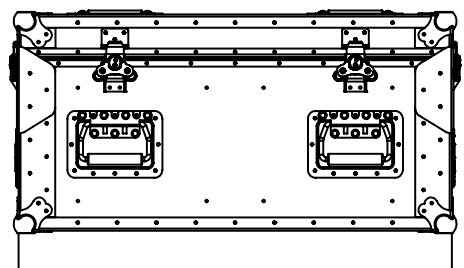
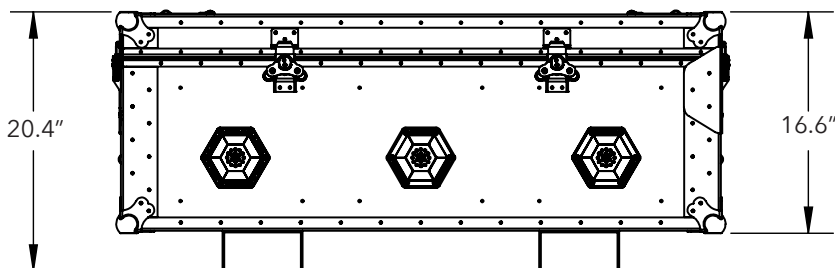
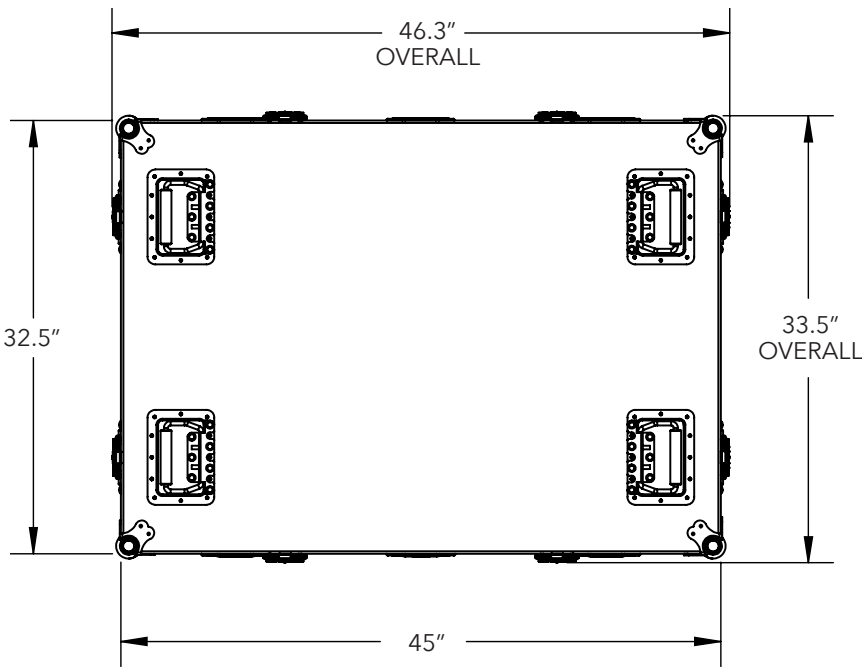

UN Mark	4B/X377/S/**/USA/M6484 ** year of manufacture
Exterior Dimensions	46.3" x 33.5" x 20.4"h 117.6cm x 85cm x 51.8cm
Interior Dimensions	6 Battery Compartments Each: 11.1" x 10.6" x 9.9"h 28.2cm x 26.9cm x 25.1cm h
Tare Weight	246 lbs 112 kg
Max. Content Weight	585 lbs max. 265 kg max.
Gross Weight Limit	831 lbs max. 377 kg max.