



# XLarge II Case CBSTC5232



20 kWh  
ECR

## Proven Safety for Battery Storage and Shipping

The premier solution for preventing and containing hazardous battery fires. The CellBlock 5232 XLarge Case is capable of accommodating large-format batteries and offers extreme protection against lithium-ion thermal events with 360° fire suppression coverage for all of its contents.

A double-walled system is paired with CellBlock’s proprietary fire panels for exceptional thermal protection. The pressure relief system mitigates smoke and fumes and eliminates risk of explosion due to overpressurization.

- ✓ Patented FCP Technology
- ✓ CellBlockEX<sup>®</sup> deployment
- ✓ Gas mitigation
- ✓ Heavy-duty stabilizing locking feet and fork lift glides
- ✓ Optional battery support tray
- ✓ Thermal and ballistic protection
- ✓ Safe and compliant transportation of batteries, including damaged, defective, and prototype.
- ✓ DOT Special Permit 20549 and 21142
- ✓ P911/LP906 tested and certified
- ✓ Optional fire suppression pillows
- ✓ Optional TAS (Thermal Alert System)
- ✓ UN rating pending



**Tested beyond compliance.** We subject our cases to “worst-case scenario” testing.

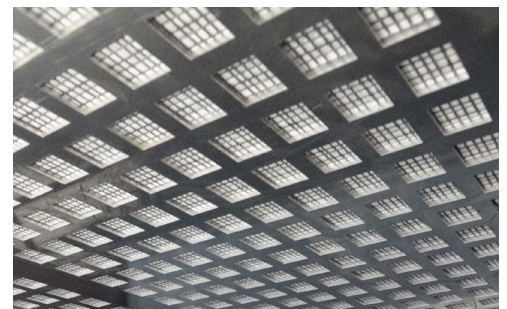

Effective suppression with a self-deployed extinguishing system featuring **CellBlockEX Technology**

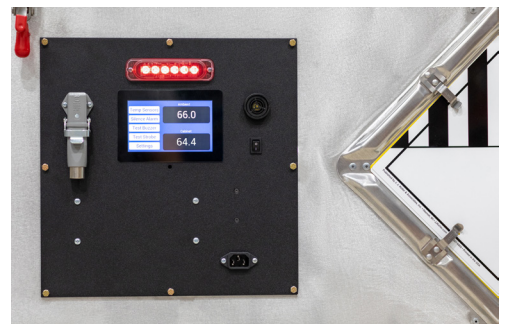

**Available with TAS** (Thermal Alert System) to provide proactive battery fire detection.

# CBSTC5232 SPECIFICATIONS

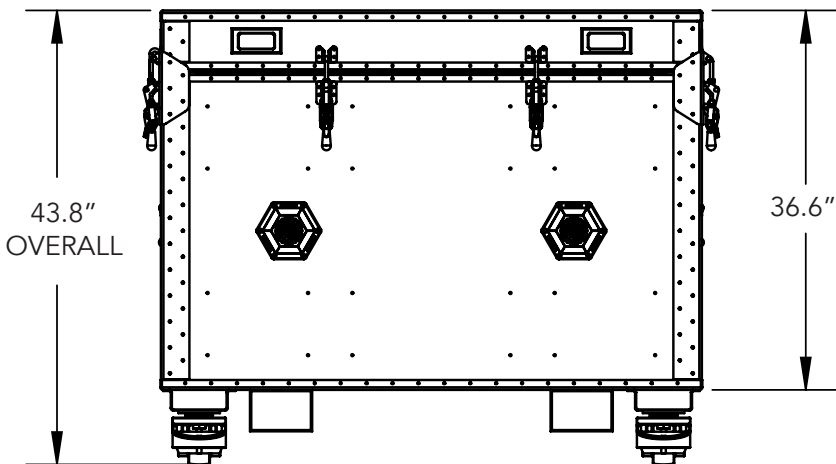
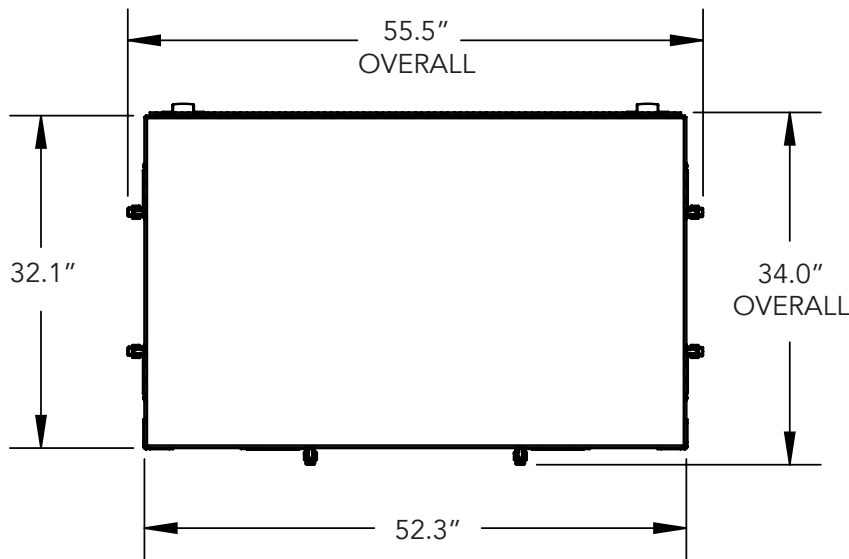
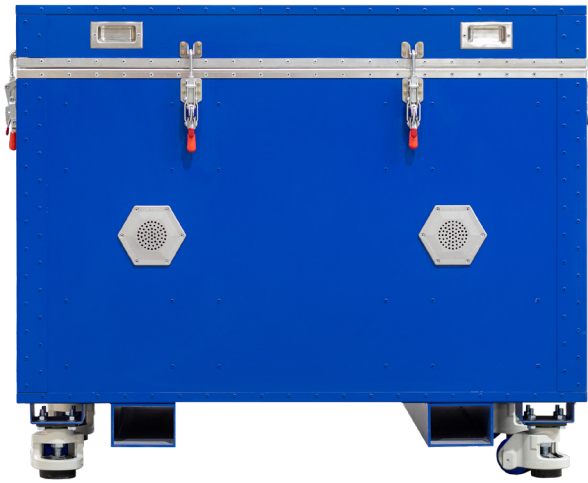

UN Mark	Pending
Exterior Dimensions	55.5" x 34" x 43.8" h 140.1cm x 86.4cm x 111.3cm
Interior Dimensions	47" X 26.8" X 30" h 119.4cm x 68.1cm x 76.2cm
Tare Weight	463 lbs max. 210 kg max.
Max. Content Weight	Pending
Gross Weight Limit	Pending

